



METRIX

MSA1-BT Audio System For Memphis Shades “Batwing” Model Fairings*

**Although This Kit Fits All Models Of Memphis Shades Batwing Fairings, It May Not Fit Your Bike Due To Gauges Or Other Components That May Be In The Way.*

**If You Are Not Sure Of The Fit On Your Bike, Please
Consult Your Dealer Before Going Any Further**

Rev 1.1

Congratulations and thank-you for your purchase of Hogtunes MSA-1-BT audio kit for Memphis Shades “Batwing” fairings! We want your new kit to work as well as it was designed to, so if you have any questions or concerns, we are here to help. Email info@metrixaudio.com, or call us during regular business hours (EST) at (608) 554-7631 in USA or (705) 719-6361 in Canada. If you still need help, please consider a professional installation by your dealer.

Please read the entire manual before starting. Identify the parts of the kit. The main parts are: main pod, grill, mounting “shoulder nut”, clamps/collars, and the “control box”.

Steps 1 and 2 will be easier if the fairing is off the bike.

Step #1: Remove the stock center windshield screw, nut, washer, and nylon spacer from the Memphis Shades fairing.

Step #2: Remove the grill from the main pod body of MSA1-BT. You will see a rubber piece on the back of the pod with a Hogtunes logo in it. Line the main pod up to the center of the windshield so the windshield will go between the back of pod and rubber part. Lift the whole pod in an upwards motion so the windshield is sandwiched as described. Make sure the wires on the back of the main pod are accessible. Place the supplied black mounting “shoulder nut” (shown below) so the threaded opening goes through the mounting hole in the center of the pod, the fairing, and the windshield. It will only go in one way. Using the supplied bolt, secure the MSA1-BT pod to the fairing. Install the fairing to the bike.

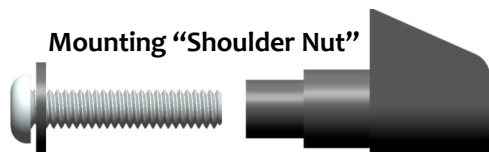

Step#3: Mounting the Control Box: The control box can be mounted anywhere on the bars, but careful consideration must be given to the operator safely adjusting the control buttons while the machine is still or in motion. The kit comes with “collars” that adapt the handlebar clamp to fit 7/8”, 1”, or 1.25” diameters and only fit one way. As shown below, the screw that must be used closest to the ball socket is the longer

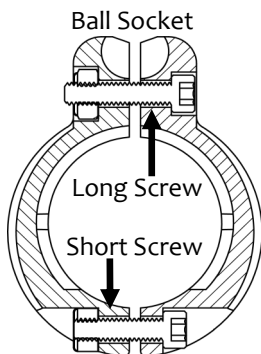

started on the screws. If not already installed, screw the “threaded ball” into the back of the main control box that works best for you. NOTE: This kit comes with a 1” threaded “standoff” that allows more options for mounting. Using “BLUE” thread lock material will help keep things secure. Once you have the screws on the clamps started, and the control box sitting how you like it, tighten the long screw closest to the ball socket FIRST. This will secure the ball to the socket best. Once the top (longer) screw is tight, tighten the shorter screw at the bottom of the clamp. This will properly tighten the clamps to your bars.

If the supplied clamps will not work for your application, the threaded inserts on the back of the control box are a standard 1/4-20 thread pattern which allows the use of Ram® Mounting systems or other custom mounting. **IMPORTANT: The thread length going into control box must not exceed 1/4" (7mm).**

Step#4: On the main wire harness, there is a 12 pin connector on one end which gets plugged into the main control box. There are 2 connectors that mate to the plugs on the back of the main pod. Plug these connectors into the main pod.

Step#5: The orange wire is a “turn on lead” that tells the control box to turn on or off with the “ignition on/off” of the machine. Switched power means the factory wire you choose is 12v positive with bikes ignition on, and zero volts with ignition off. Using your machine’s owners manual, locate a switched power source such as an ignition switch, headlight switch or a switched power location in the fuse panel and attach the orange wire to this. The orange wire must see switched positive 12 Volt DC for the system to operate. Please ensure good connections to avoid unnecessary non-warranty claims.

Step#6: Route the positive (red) and negative (black) wires towards the machines battery. Working from the control box towards the battery, cable tie these 2 wires to the machine. Attach the red wire to the positive connector on your battery. Attach the black wire to the ground connector on your battery. Please ensure good connections to avoid unnecessary non-warranty claims.

IMPORTANT: Make sure the installation of any components or wires does not impede the steering or operation of the machine! Failure to do so can cause an accident resulting in serious injury or death!

The system is now ready to test. To get started, turn any bass boosts, loudness contours or volume limiters on your audio device OFF! Put the volume of your audio device to one “click” below maximum. **Note:** The overall volume and performance of this system heavily relies on the quality of the music files the and the quality of the audio device used to provide the music.

Pairing Bluetooth® wireless technology device to the control box: When the control box sees power, it will try and pair with a device for up to 2 minutes as shown by the flashing Bluetooth® logo. Go into your audio devices settings menu, and accept the pairing to the “Metrix Audio MA4BT” system. When paired, the Bluetooth® logo will stay on solid blue. If nothing is paired, after 2 minutes, the Bluetooth® logo will go out. The unit must be turned off, and then back on to resume pairing mode. **Please Note:** Depending on the music device, when it first pairs to the control box and starts to play, the system may sound like a CD is skipping for a few seconds. THIS IS NORMAL. Your audio device is getting its wireless communication “in sync” with the MA4-BT.

Using zip ties, secure all wires to the machine. Work your way back to the battery location making sure any slack is taken up without impeding any steering or other controls. Avoid having any cables too close to extreme heat areas. In most cases, the supplied power (red) and ground (black) wires are plenty long. If you have extra wire, we suggest bundling any extra and securing well with zip ties.

Control Box Functions

Audio Input: MSA1-BT accepts audio in by 2 different methods, one being via Bluetooth® wireless technology, the other being “line level input” via the female mini jack wire on the control box. When the control box is playing via line in, “Mode” is illuminated. When the control box is playing via Bluetooth®, its blue logo is illuminated. You can have a wired line in device and Bluetooth® working at the same time but only one device can be heard depending on what the Mode button is set to.

Volume + / - buttons: Pushing the “Volume +” increases the volume of the system, and “Volume -” reduces the volume. The volume buttons are active in both Bluetooth® and line in modes. Please Note: If you hear an audible “beep” through the system when you are pushing the Volume + button, this indicates you have reached the maximum volume of MSA1-BT . You “may” be able to get additional volume by adjusting the volume level of the music playback device.

Track+ / - buttons: When in Bluetooth® mode (only), these buttons allow you to skip tracks forward or backwards remotely on your paired music player. Depending on the music device, you will have to figure out how to go back to the start of the song your listening to vs the start of the last song you listened to. In most cases pushing the “track -” button once will take you back to the start of the song you are listening to, and pushing it twice within a second will take you to the start of the previous song.

Play/Pause Button: When in Bluetooth® mode (only), this button allows you to pause (mute) music, and restart remotely on your paired music player.

“Folders” on your music device: If you play music from within a file folder on your music device , MSA1-BT can only play music from within that folder. MSA1-BT cannot automatically “skip” from folder to folder in your music devices file system.

Final Audio Adjustments:

How your system sounds sitting still will be RADICALLY different from how it sounds “at speed”. The music playback device may have equalizers or other audio adjustments built in that can be tested until you find the one that works for you. The best way to make the system sound good is to use GOOD QUALITY music files. “Borrowed” music from most free sharing sites will typically play quieter and sound the worst.

Adding Additional Amplifiers To Your System:

There is a 4 pin blue plug attached to the main wire harness. This can be used to send a full range audio output to “drive” the input of any amplifier that has “hi level input”. This gives the ultimate flexibility as you can continue to have the supplied speakers be powered by the MA4-BT main unit, and then have an amplifier power other speakers such as saddlebag lid speakers or even subwoofers.

DO NOT WIRE ADDITIONAL SPEAKERS DIRECTLY TO THIS AUDIO OUTPUT!

**Wiring Speakers Directly To This Plug Will Damage The Control Box
Which Will Not Be Covered By Warranty**

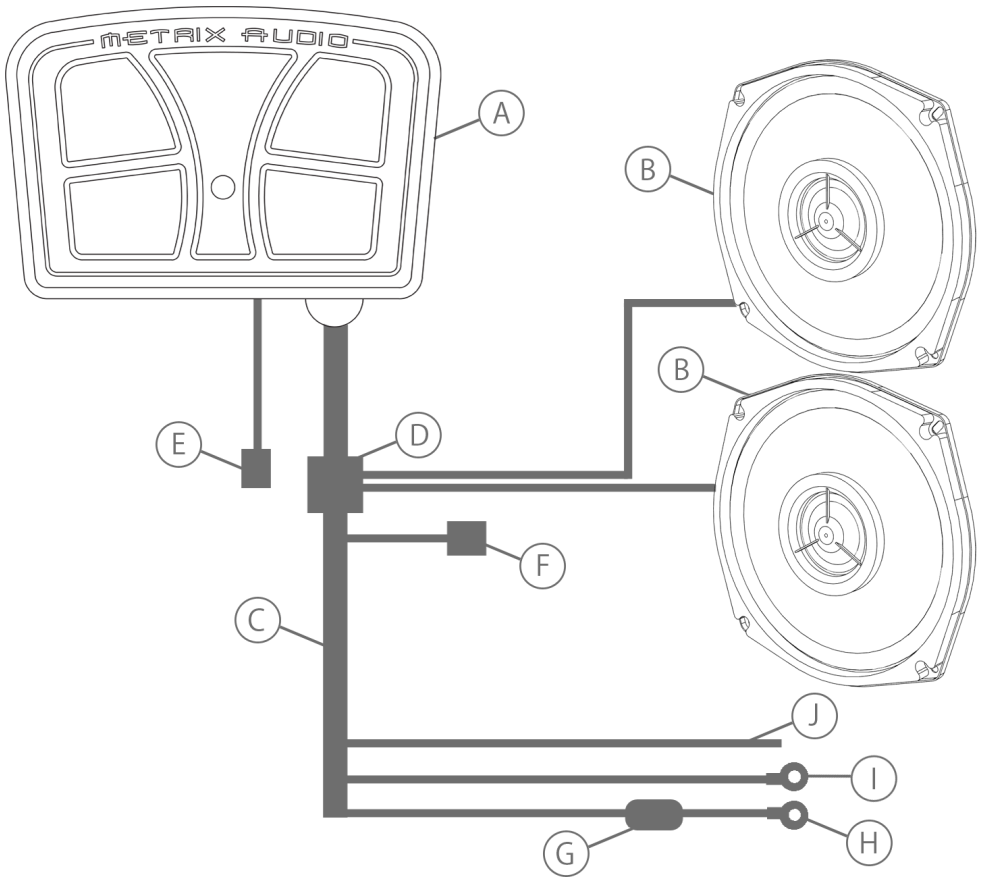

System Flow Chart

- A) Main Control Box
- B) Speakers (in “Pod”)
- C) Main Wire Harness
- D) 12 Pin Harness Plug
- E) 1/8” (3.5mm) Auxiliary Line Level Input
- F) Hi Level Audio Output for Adding Amplifiers
- G) 5A mini AGU fuse holder
- H) Main Power Wire (Red)
- I) Main Ground Wire (Black)
- J) Remote Turn On Wire (Orange)

Warranty Information:

Metrix Audio's MSA1-BT is warranted for a period of 12 months from the original purchase date. The warranty applies to the original (retail) owner of the system only. Proof of purchase is required for all warranty claims. Please visit the warranty section of our website and fill out the form, or email or phone us. Products found to be defective during the warranty period will be replaced (with a product deemed to be equivalent) at Metrix Audio's sole discretion. Metrix Audio and Houghtunes Inc are wholly owned subsidiaries of Powersports Audio Inc., Barrie, Ontario, Canada.

USA Tel: 608-554-7631

Canada Tel: 705 -719-6361.

email info@metrixaudio.com

What Is Not Covered:

- 1) Any expense related to the removal or re-installation of this system.
- 2) Warranty to products with missing or defaced serial numbers.
- 3) Damage due to improper wiring
- 4) Repairs of any kind performed by anyone other than Metrix Audio.
- 5) Subsequent damage to any other components.
- 6) Any product purchased from a non-authorized Metrix Audio dealer.
- 7) Damage from an accident or collision.
- 8) Damage from any custom mounting.
- 9) Damage from obvious submersion in water or any other liquid.



The Bluetooth® word mark and logos are registered trademarks owned by Bluetooth SIG, Inc. and any use of such marks by Hogtunes Inc is under license. Other trademarks and trade names are those of their respective owners.



Any audio system can be a distraction to the rider and/or passenger. Please use caution when playing your stereo, especially in traffic.